

AMBIENT AIR IN.
REUSABLE FILTER:
1) SLIDING FRAME STANDARD
2) OPTIONAL 2" FILTER

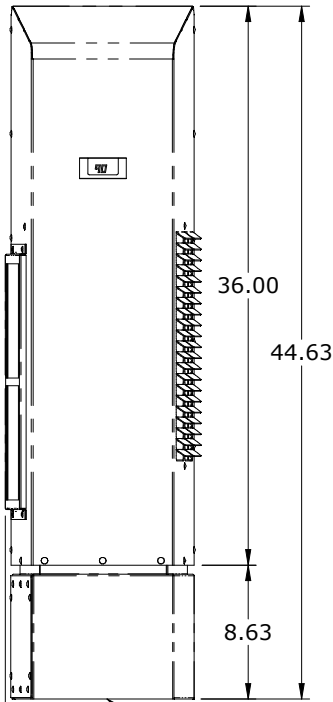

CONDENSATE EMERGENCY OVERTFLOW
11/16-16 STRAIGHT THREAD
MAXIMUM THREAD DEPTH .31"

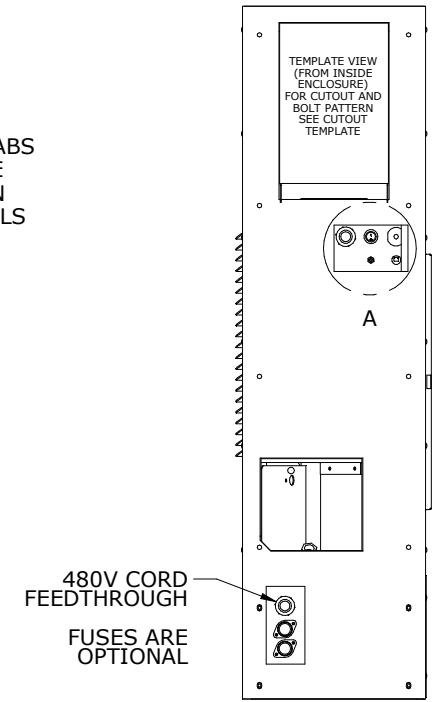
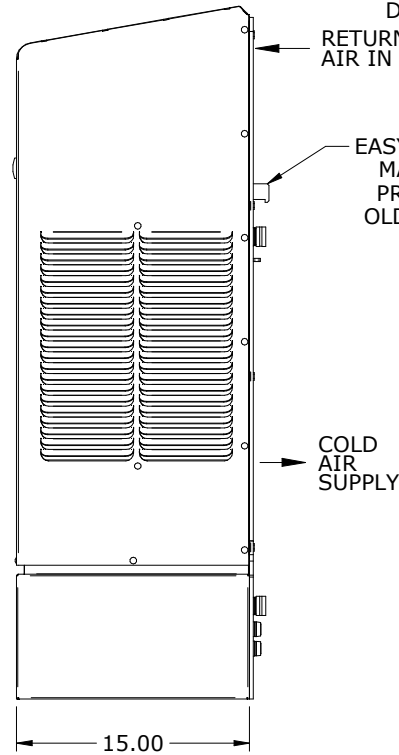

TITLE		
NARROW EDGE 480 V NE050-486		
136 1/08	DWG NO NE050-486	REV
SCALE	WEIGHT	SHEET 1 OF 1